

Threading of the lower looper, green path

The lower looper should always be threaded first.

Pull the thread through the guides 1 to 12.

At step 5 pull with both hands the thread into the tension discs.

At step 10, turn the handwheel towards you, so the lower looper is on the left.

Thread guides 10 and 11.

Turn the handwheel again so the looper is on the right side and thread guide 12.

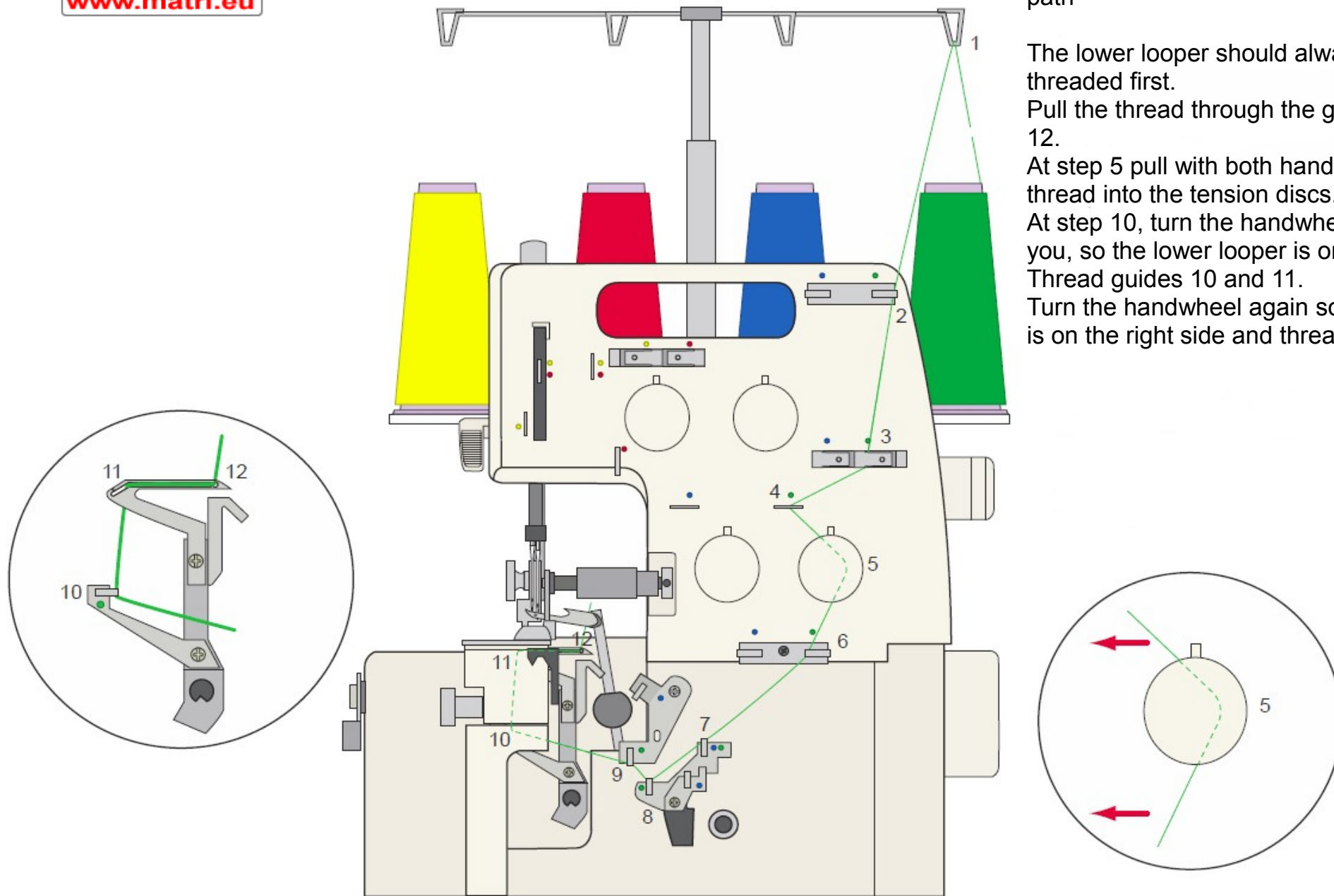



www.matri.eu

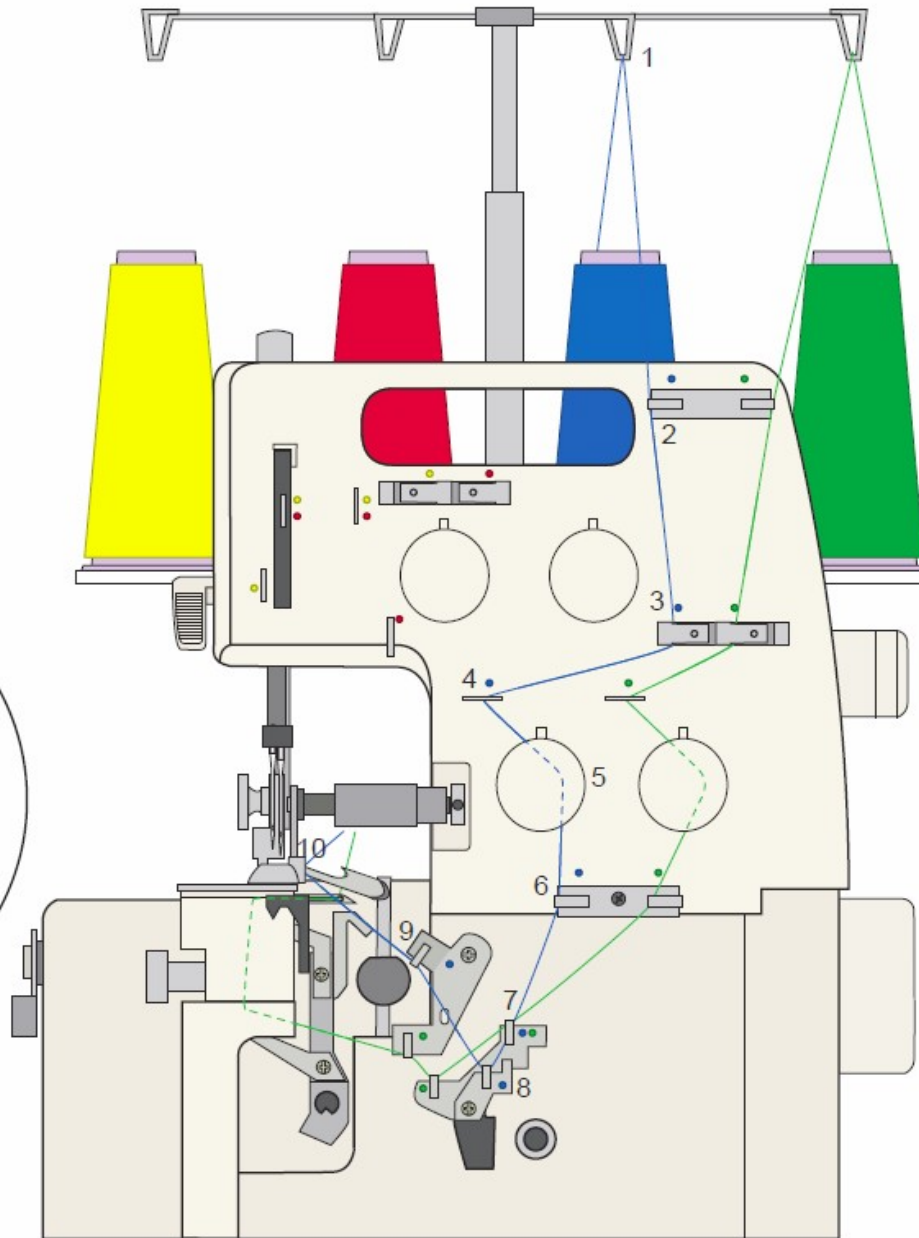
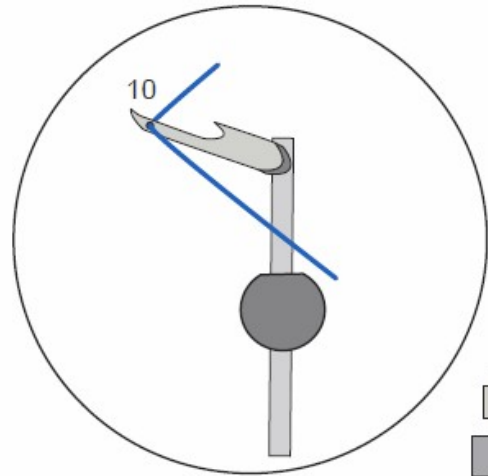

Threading of the upper looper, blue path

Put upper looper in the highest position by turning the handwheel.

Thread the guides 1 to 10.

At step 5, pull the thread with both hands into the tension discs

At step 10, turn the handwheel so the hole of the upper looper is visible and thread with help of tweezers.

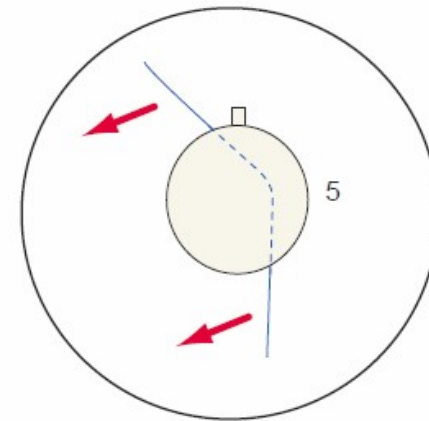



www.matri.eu

Threading of the right needle, red path

Thread the guides 1 to 8.

At step 3, pull the thread with both hands into the tension discs.

At step 8, turn the handwheel so the needles are in the highest position.

Thread the right needle.

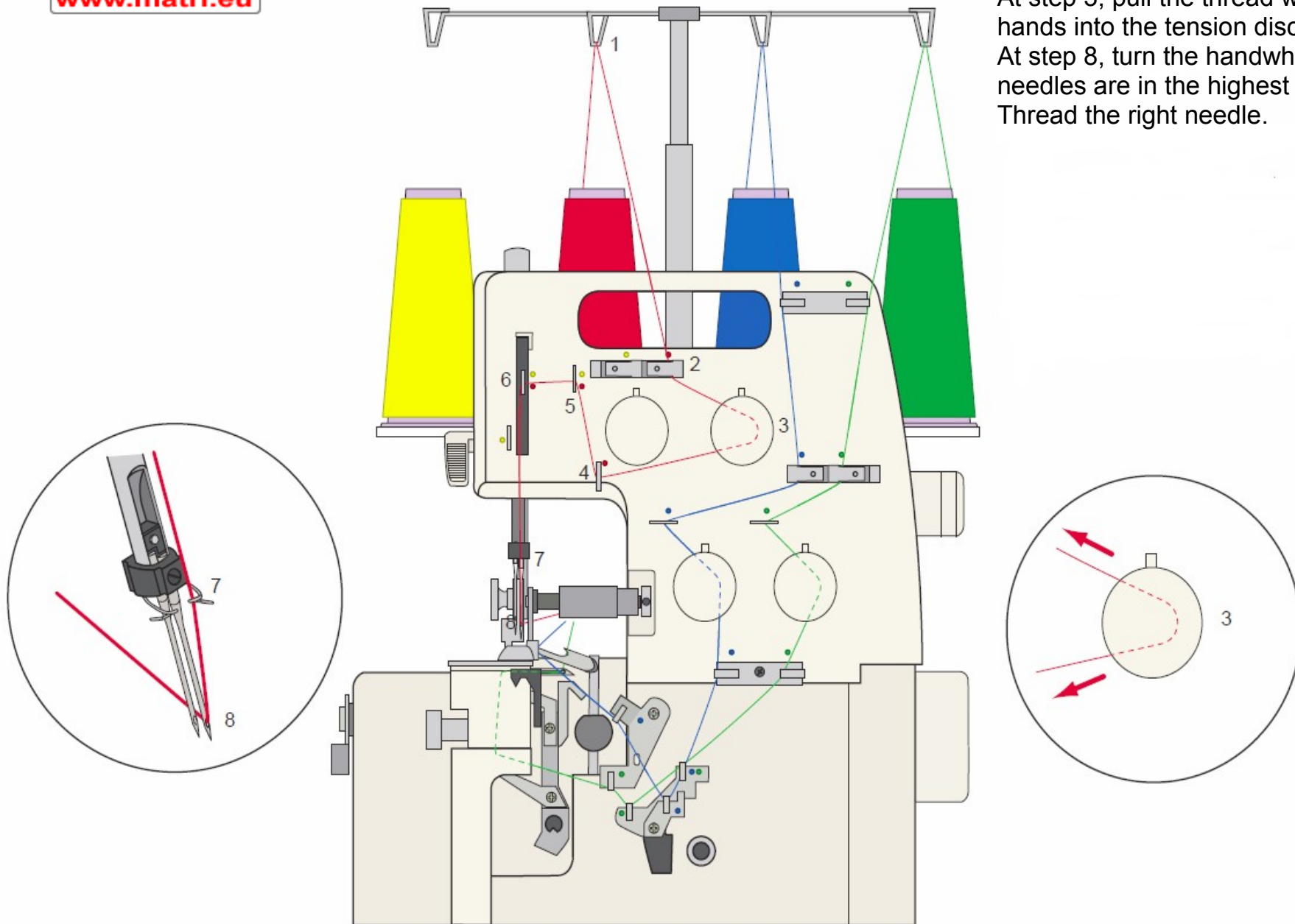

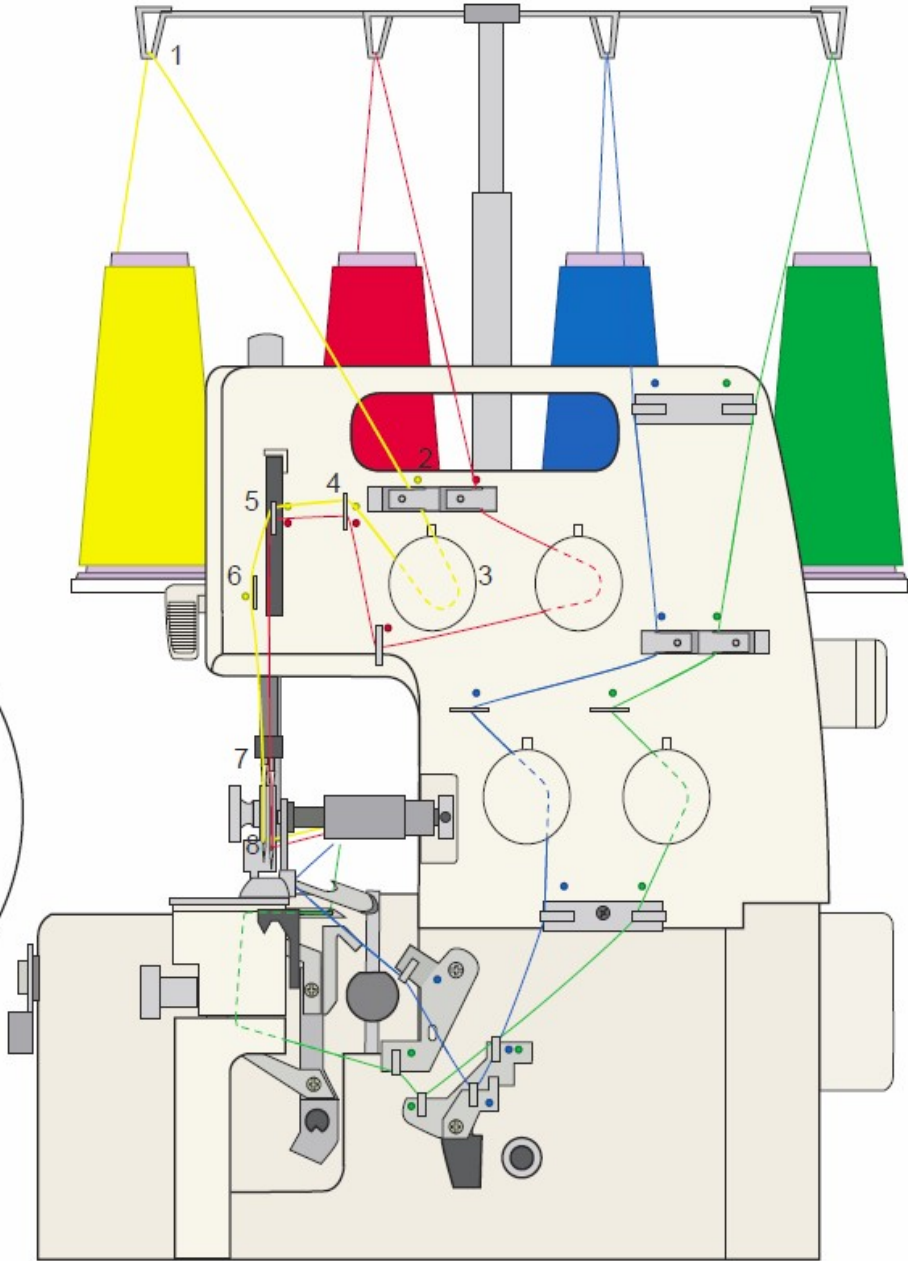

Threading of the left needle, yellow path.

Thread the guides 1 to 8.
At step 3, pull the thread with both hands into the tension discs.
At step 8, bring the needles into the highest position by turning the handwheel.
Thread left needle.

